

# ShopFan

## Technical Specifications

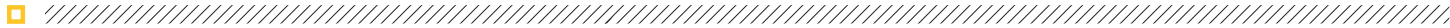

Lightweight and pre-wired for easy installation, ShopFan by Big Ass Fans® is an impressive and economical fan package for workshops, small manufacturing facilities, and industrial spaces. Easy installation, superb performance and year-round energy savings — just what you'd expect from Big Ass Fans.



### EASY INSTALLATION FOR SMALLER SHOPS

- **Convenient Installation** — Lightweight and pre-wired for easier, faster installation; plug and play in any 110–125 V, 20 A receptacle
- **Airfoils** — Six patented aluminum airfoils (mill finish)
- **Winglets** — Cuffed winglets eliminate wind noise (safety yellow)
- **Motor and Gearbox** — Industrial-grade motor and gearbox feature inline helical-cut gears for efficient, durable, and reliable operation; lubricated for life with synthetic oil
- **Hub System** — Machine-cut precision components for uniform load distribution
- **Controller** — NEMA 4X variable speed drive is pre-wired to the motor with a 50 ft (15.2 m) cord and includes a 10 ft (3 m) AC supply power cord
- **Mounting** — Standard mount with 36 in. (914 mm) extension tube install to I-beams and angle iron; optional kits allow for mounting to large I-beams, solid beams, Z-purlins, and pitched roofs
- **Safety Features** — Airfoil retainers, hub retainer clips, safety cables, Grade 8 bolts, fire relay (must be wired if required by local code)
- **Efficiency** — Moves more air than 70 standard ceiling fans at just a fraction of the operating cost



The unique aerodynamic design eliminates vortex formation at the airfoil tips.

Technical Specifications							
Diameter (A)	Weight <sup>1</sup>	Max speed	Airfoil clearances <sup>2</sup>	Input power and required breaker	Max amps	Motor	Sound at max speed <sup>3</sup>
14 ft (4.3 m)	145 lb (65.8 kg)	101 RPM	10 ft (3 m) above floor 2 ft (0.6 m) on sides 5 ft (1.5 m) below ceiling deck	100–125 VAC, 50/60 Hz, 1 Φ, 20 A	11 A	1.0 hp (0.75 kW)	< 55 dBA

<sup>1</sup> Weight does not include mount or extension tube.  
<sup>2</sup> Measure the distance from the tip of the winglet to the ceiling or major obstruction.  
<sup>3</sup> Fans are sound tested at maximum speed in a laboratory environment. Actual results in field conditions may vary due to sound reflecting surfaces and environmental conditions.

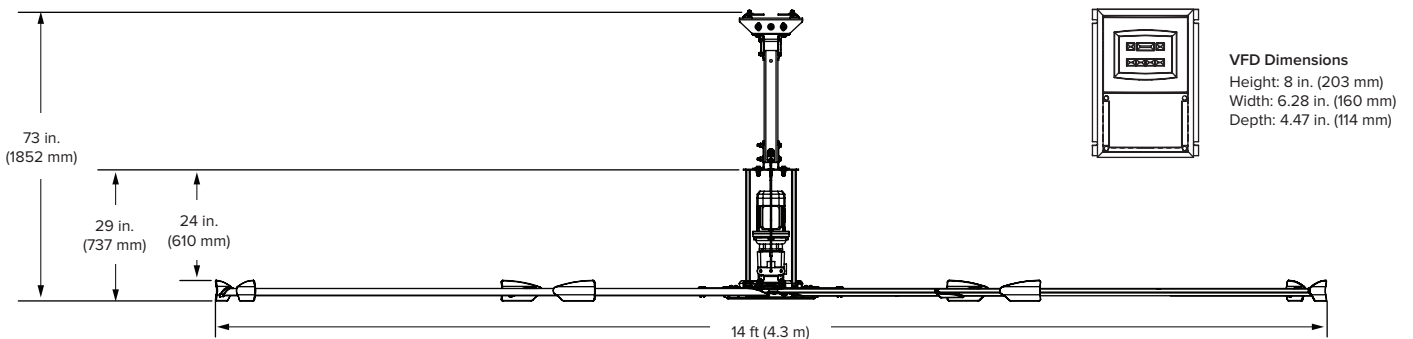

VFD Dimensions  
 Height: 8 in. (203 mm)  
 Width: 6.28 in. (160 mm)  
 Depth: 4.47 in. (114 mm)



Certified to UL 507 and CSA C22.2

Lead times may vary.  
 See full warranty for coverage information.  
 Specifications subject to change without notice.



USA  
 BIGASSFANS.COM  
 877-244-3267

CANADA  
 BIGASSFANS.COM  
 844-924-4277

AUSTRALIA  
 BIGASSFANS.COM/AU  
 1300 244 277

SINGAPORE  
 BIGASSFANS.COM/SG  
 65 6709 8500

MALAYSIA  
 BIGASSFANS.COM/SG  
 603 5565 0888